

A

B

C

D

E

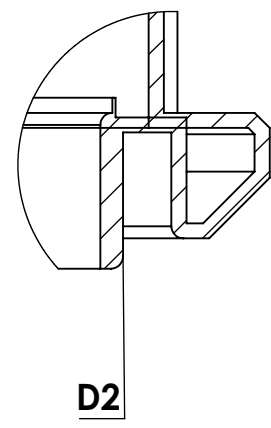
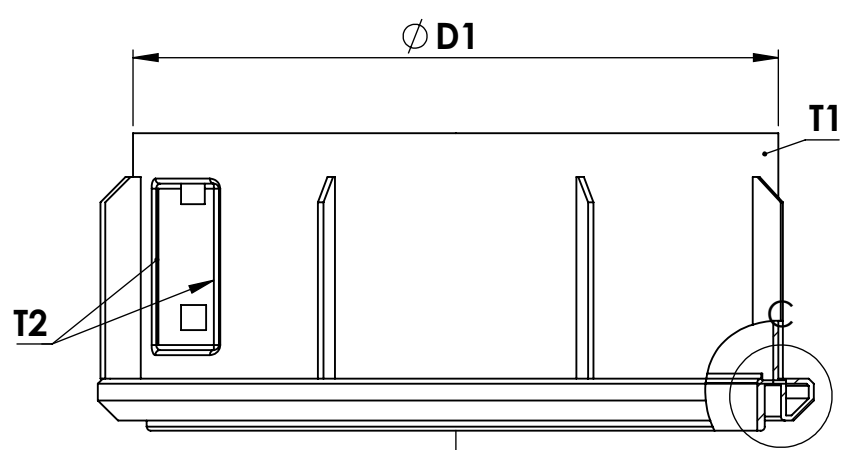

DETAIL C
SCALE 1 : 5

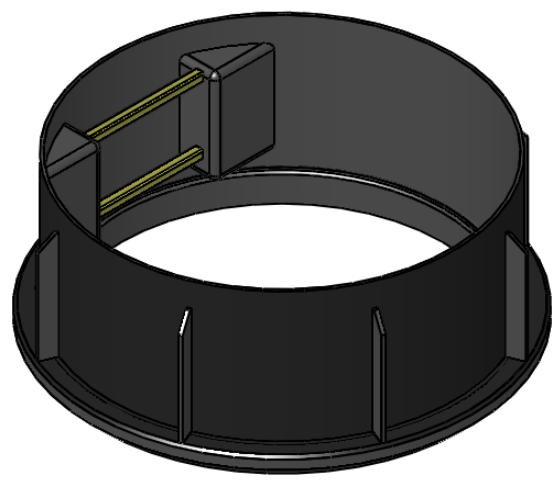
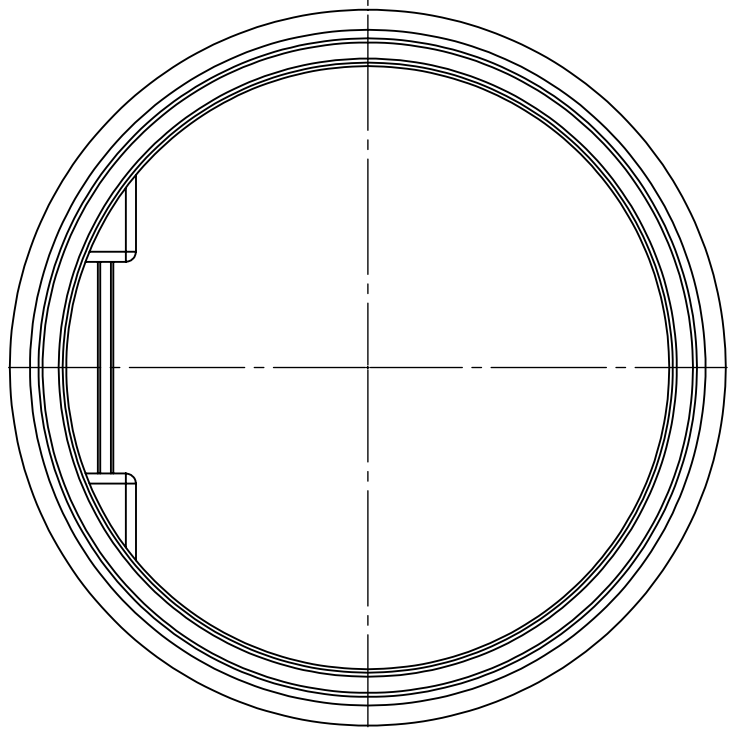

UNLESS OTHERWISE SPECIFIED:
DIMENSIONS ARE IN MILLIMETERS
SURFACE FINISH: N8
TOLERANCES: +/-2%

חופית קיבוץ כנרת
ד.ב. עמק הירדן 15118
tel.+972-4-6759530/1/2 F.+972-4-6759518



	NAME	SIGN.	DATE	REV.
DRAWN	עופר I		11/01/2016	A
CHK'D				
APPV'D				
Q.A				

הגבהה קוטר 125+מדרגות
גובה 50
0211-EPS1205

MATERIAL: PE
FINISH:
Remark:

DWG. NO.
CAT. NO.